



# CAULKING & WEATHERSTRIPPING

Minnesota Department of Commerce Energy Information Center

Air leakage can account for one third of the total heat loss in an average home. Warm air leaking out must be replaced with cold air drawn in, which has to be heated. Excessive air leakage may be costing you more than \$100 every year if you are heating with natural gas, and even more with other fuels. Moisture also escapes with the warm air, and if it condenses inside the walls or in your attic, serious structural damage could result. Caulk and weatherstripping are materials designed to stop these air leakage heat losses, and can pay for themselves in less than two years if the installation is done with care. Caulking and weatherstripping offer other benefits as well, including the ability to weatherproof the exterior of your home, control moisture-laden air from damaging the home's structure and prevent the discomfort of cold drafts.

Locating air leaks

Weatherstripping doors and windows

Applying caulk

Choosing caulking and weatherstripping materials



Add up the small cracks and holes in your home and you could have the equivalent of a two-square-foot hole. This is like leaving a small window open all winter!

Before you begin your project, call the Energy Information Center and ask for the Home Energy Guide "Combustion Air." Appliances and fireplaces that burn wood, gas or oil, such as a furnace or water heater, need fresh air for proper combustion and exhaust. Unless you have recently replaced the furnace and water heater with a new sealed combustion or direct vent type appliance, you have a natural draft exhaust system.

*Warning: It is possible to alter the air leakage of the house enough to cause problems with a natural draft exhaust system.*

Back drafting, poor combustion and dangerous build-up of combustion gases (including carbon monoxide) within the house is possible. Read the Combustion Air guide and follow its recommendations. Also, install a carbon monoxide (CO) detector near bedrooms.

Locate the air leaks

Weatherstripping can be used to control air leakage at joints where two surfaces meet and move relative to each other, such as windows and doors. Weatherstripping is often the easiest and least costly way to control heat losses by air leakage, and it improves indoor comfort by reducing cold drafts.

The first step in weatherstripping is to determine where the air is leaking from your home. Common sources of air leakage are shown in Figure 1. Air leakage can be detected by holding a smoking object, such as an incense stick, or a thin piece of thread, near doors, windows and vents (see Figure 2). Drafts are shown as the thread or smoke moves with the air currents. Your electric or gas utility may provide a residential energy audit service which often includes a "blower door test." The test involves using specialized equipment to pressurize your house, which will measure the air leakage characteristics of your house and help identify the leaky spots. Consider this test only if you have installed a CO detector.

#### Related Guides

- Attic Bypasses
- Combustion & Make Up Air
- Home Heating
- Home Cooling
- House Diagnostics
- Low Cost/No Cost Ideas
- Windows & Doors
- Indoor Ventilation
- Home Insulation

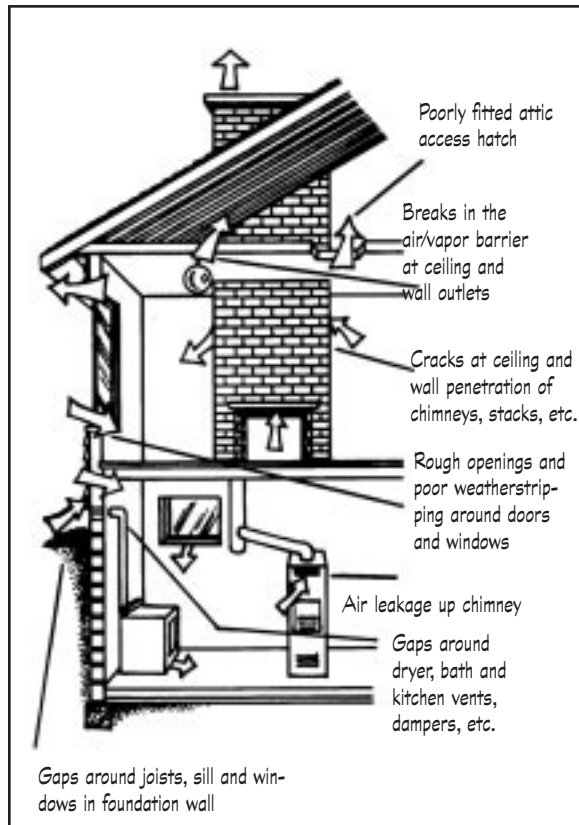

Figure 1:  
Common air leakage sources

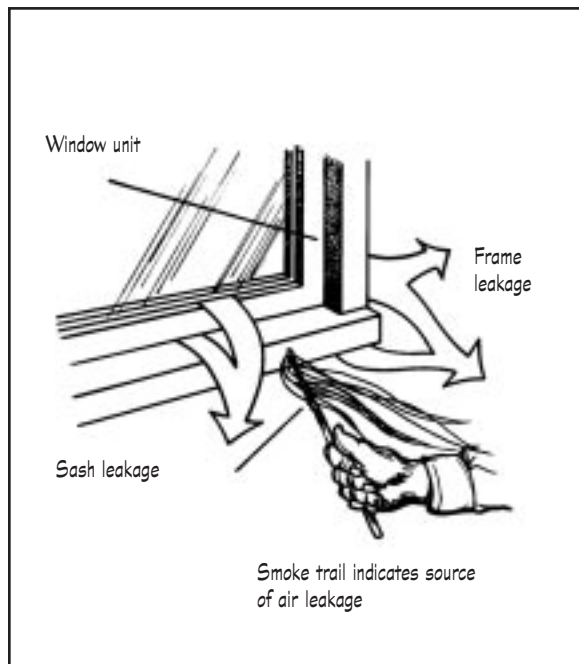

Figure 2  
Test for air leakage by holding a smoking object, such as an incense stick, or a thin thread, near doors, windows and vents.

For best results, choose a cool, windy day in the fall or a very cold winter day. Turn on all exhaust fans and the furnace and clothes dryer. This will increase the pressure difference and draw air out of the house so that outside air will come in at the air leakage points to replace it.

Move the thread or smoke source around window and door edges, electrical outlets and other potential leakage areas identified in this guide, and mark the drafty spots with chalk. Check the drafty areas on windows and doors to determine if there is any weatherstripping, if it is worn out and should be replaced or if it just needs adjusting.

**Weatherstripping doors and windows.** Attention to detail is critical when installing weatherstripping to avoid problems with window and door operation. Extensive testing has shown that tubular weatherstripping provides the best seal. However, on doors or swinging windows, this type requires the most closing pressure, which may be difficult for children, handicapped or elderly individuals. Silicone, neoprene, urethane, or rubber strips are better in these situations.

Open-cell foam and felt strips need to be very tightly compressed to create an adequate seal. They will keep out dust, but are inadequate air barriers. Therefore, this publication highlights the installation of neoprene, urethane, silicone, or rubber strip, tubular and specialty types of weatherstripping, because these materials create good air seals with minimum closing force at all temperature ranges and have long, useful lives.

The type of window has a direct bearing on the type of weatherstripping to use. Double hung or vertically sliding windows can be weatherstripped with tubular or strip materials (Figure 3). The permanent or nonsliding sections can have air leakage eliminated with removable caulk.

Spring metal is the most durable but is difficult to install on existing windows. Tubular or plastic strips can be mounted on the inside or the outside, but in our extreme climate will last longer when installed on the inside. The meeting rails in the center of the vertical sliders are best weatherstripped with a tension strip.

Horizontal sliders are another common window; these include sliding glass doors. The ease with

## Caution

Houses built before 1978 may contain lead-based paint. The older a house is, the more likely it is to have lead-based paint and high concentrations of lead in paint. If you work on windows that have painted trim, you need to control any dust and chips from the paint and dispose of them safely. Intact paint should not be removed. Pregnant women and small children should stay away from the work area until it is cleaned up. Information on lead is available from the Minnesota Department of Health at 651-215-0890, or [www.health.state.mn.us](http://www.health.state.mn.us)

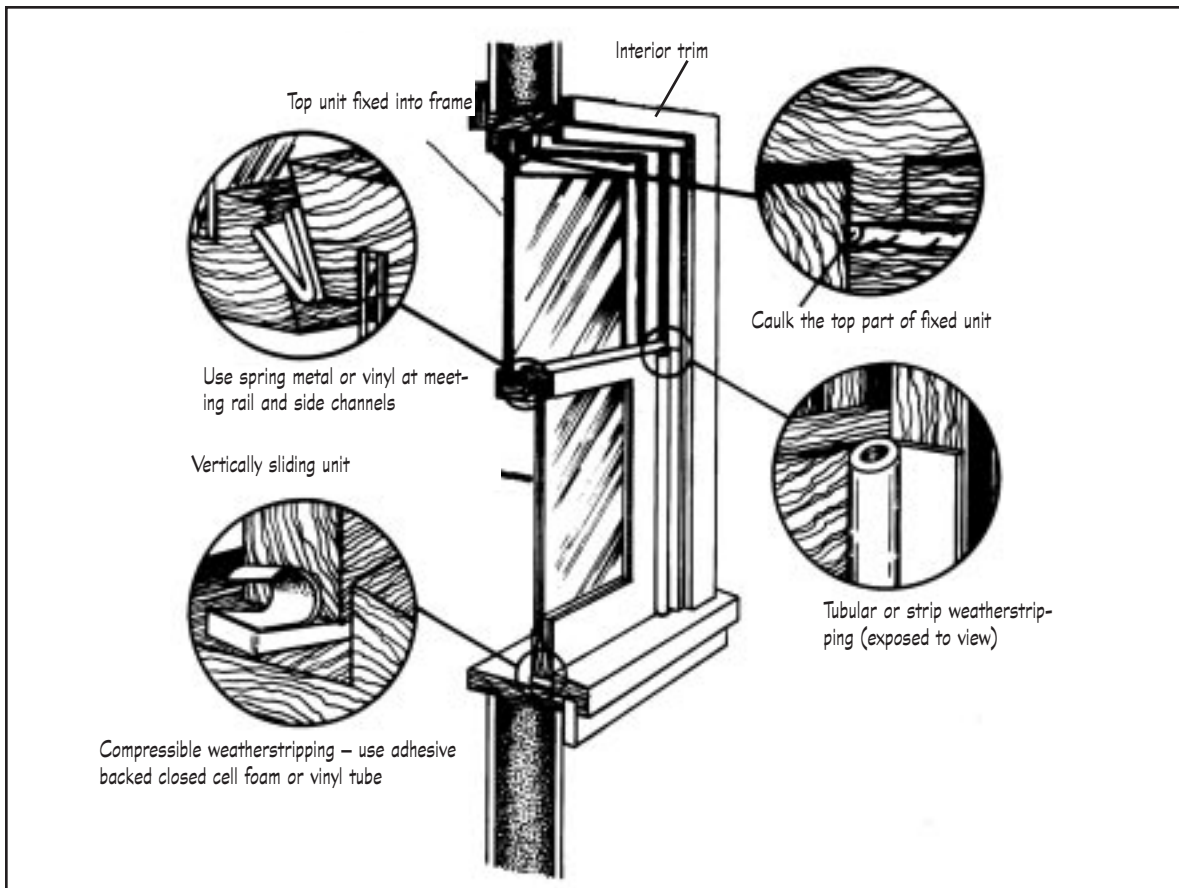
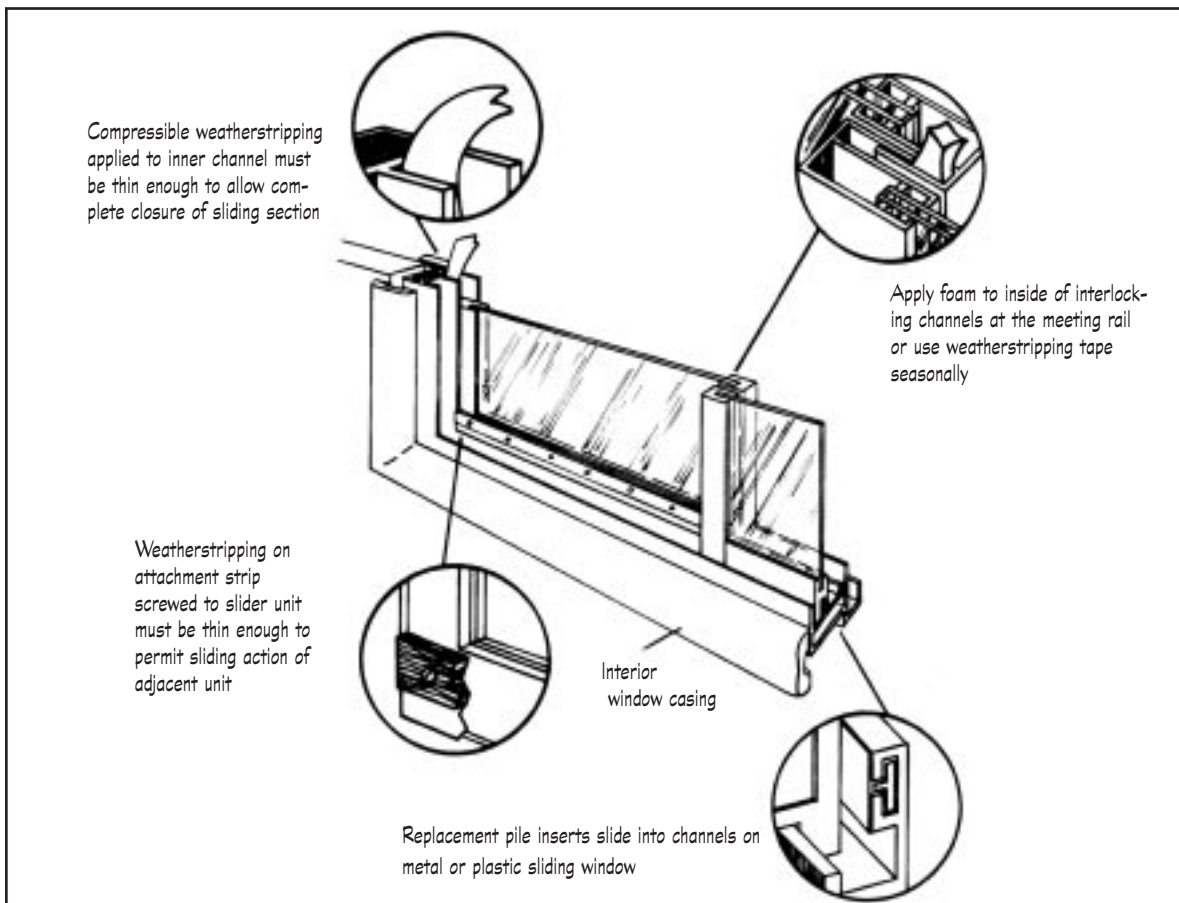

Figure 3: Typical double-hung window

Figure 4: Typical sliding window unit



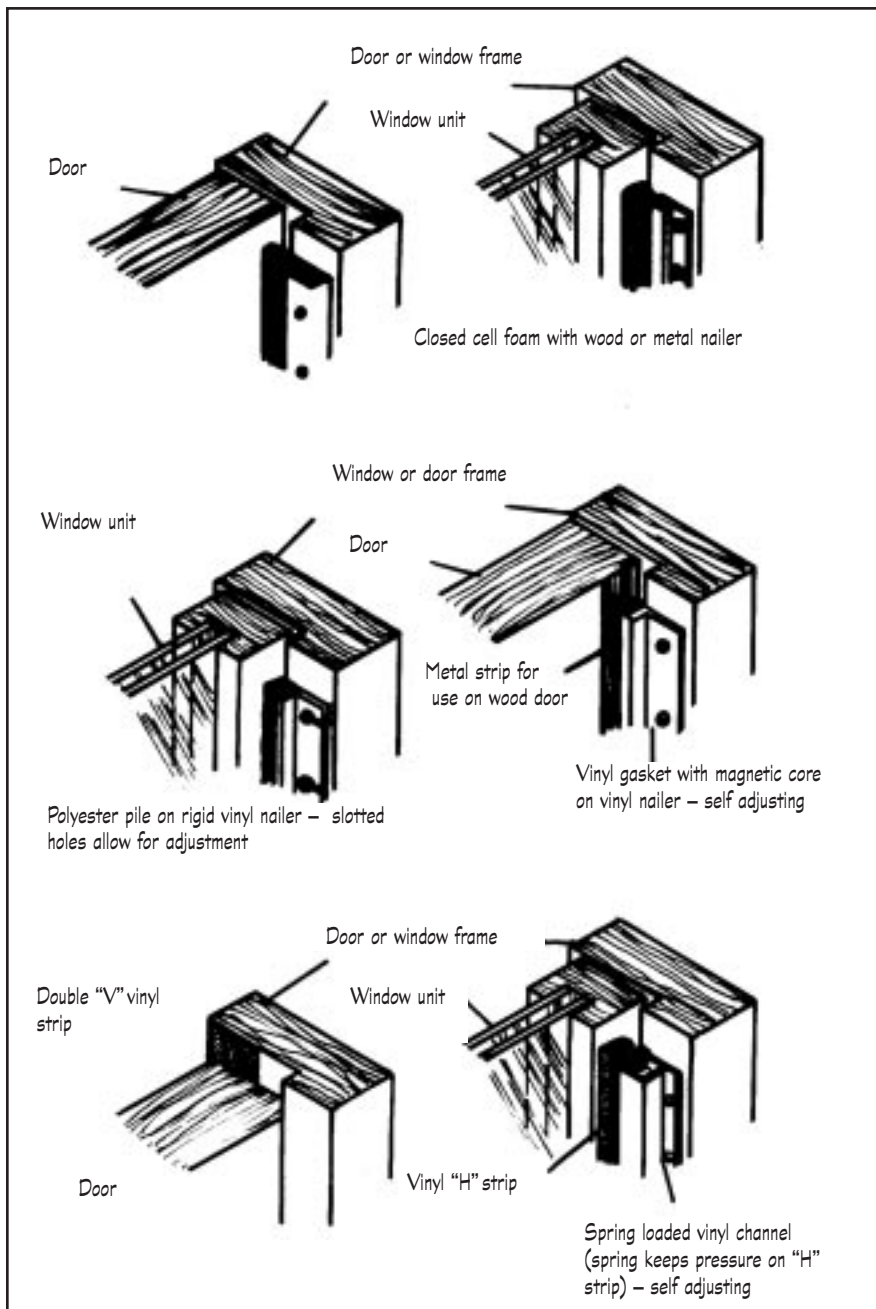

Figure 5:  
Types of weatherstripping for doors or windows without existing seals

which weatherstripping can be applied depends on the type of sash. If not previously weatherstripped, wood or vinyl-covered wood windows are usually best fitted with angled strip materials (Figure 4). If existing weatherstripping is worn out, replace it with a similar type.

Metal or vinyl sash horizontal sliders are usually weatherstripped at the factory. However, if worn out or defective, the seals can usually be replaced by sliding new material into the old channels. Be sure to measure the width required so that you purchase the correct size.

Because there are so many types of sliding windows, some innovation may be required by the homeowner. For sliding windows or doors with large, leaky gaps, seal the channels with rope caulk or sealant-peel caulk (see elastomeric caulk in Table 3) in the fall and remove it in the spring. For narrower gaps in sliding windows, a weatherstripping tape can be applied in the fall and removed in the spring.

*Warning: Always designate one window in each room as the fire escape and make sure it is operable by occupants.*

Awning, hopper or casement windows that swing open can be weatherstripped like doors. Material is attached to the jamb, and the door or window closes against it. Figure 5 shows some types of jamb weatherstripping suitable for doors or swinging windows with no existing seals. Weatherstrip all sides, including the hinge side.

Most windows of this type are factory weatherstripped, but if the materials wear out, replace them with similar types. Before replacing spring metal or metal V strip weatherstripping, pry the existing strip apart to re-spring the strip. Select a material with slotted holes or a self-adjusting one so that future adjustments can be made to accommodate change, slight movement, warping or shrinkage.

New windows often have double weatherstripping; that is, two separate seals. This concept can be applied when upgrading existing windows. For swinging windows, put one strip of weatherstripping on the edge of the sash that moves and another compression strip attached to the jamb on the inside.

For a better seal when applying any weatherstripping, clean the attachment surface and apply a



bead of caulk under the weatherstripping where it is attached to a flat surface.

**Weatherstripping bottoms of doors.** The bottoms of doors, unlike jambs, are subject to wear and therefore the weatherstrip must be more durable. There are two ways to strip this area; by using a threshold or by attaching a door bottom or sweep (Table 2).

Try to choose a threshold or door bottom that does not require trimming the door. Some will adjust to accommodate different clearances (Figure 6), but others will not. Door sweeps require no clearance, because they attach to the side of the door.

Thresholds are generally installed to replace existing worn out ones. Often only the vinyl or rubber weatherstripping is defective, not the entire assembly. Check to see if new inserts can be purchased separately. If the whole threshold must be replaced, select one with replaceable gaskets.

Door bottoms or sweeps are usually installed on doors with no existing bottom weatherstripping. They are installed flush with the floor or threshold of the existing sill to provide a positive seal against air movement. Select a sweep or door bottom that can be adjusted to compensate for wear and movement.

Because doors will change dimensions with changing temperatures, self-adjusting weatherstripping is a good choice.

**Weatherstripping other openings.** Other “door-type” openings in your home include attic hatches and mail chutes. The doors of mail chutes can be weatherstripped with the same jamb materials described for windows and doors. If the chute is no longer in use, fill the box with insulation and seal the inside door with caulking.

Attic access hatches should be weatherstripped with compressible tube or strip products installed as shown in Figures 5 and 7. If the hatch is not heavy enough for a tight seal, add weight to it, use fasteners or screw the hatch securely closed. The hatch must also be insulated adequately. Check the Home Energy guide, “Attic bypasses,” for details on sealing attic air leaks.

Other openings to the exterior include exhaust fan dampers. These cannot be weatherstripped,

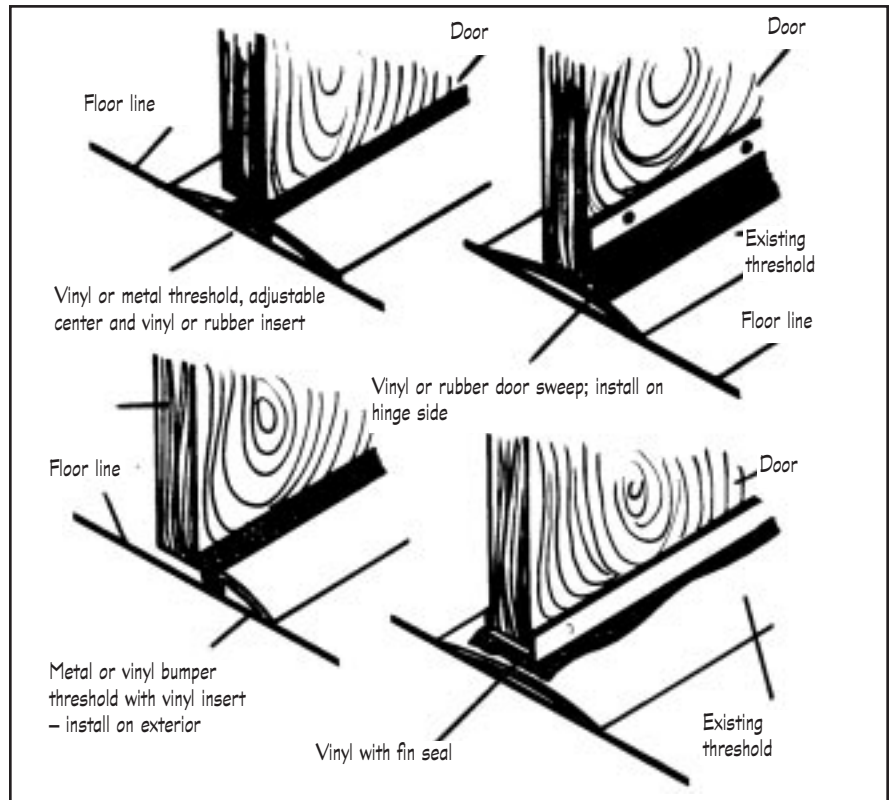

Figure 6:  
A variety of weatherstripping is available to seal the bottom of doors.

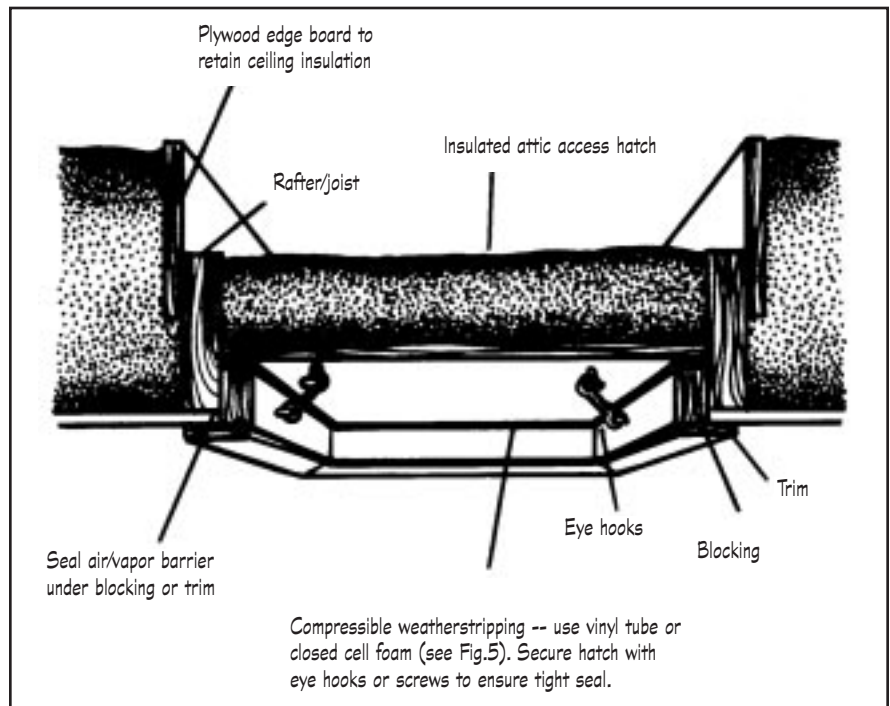

Figure 7:  
Attic hatches should be sealed to prevent air leakage.

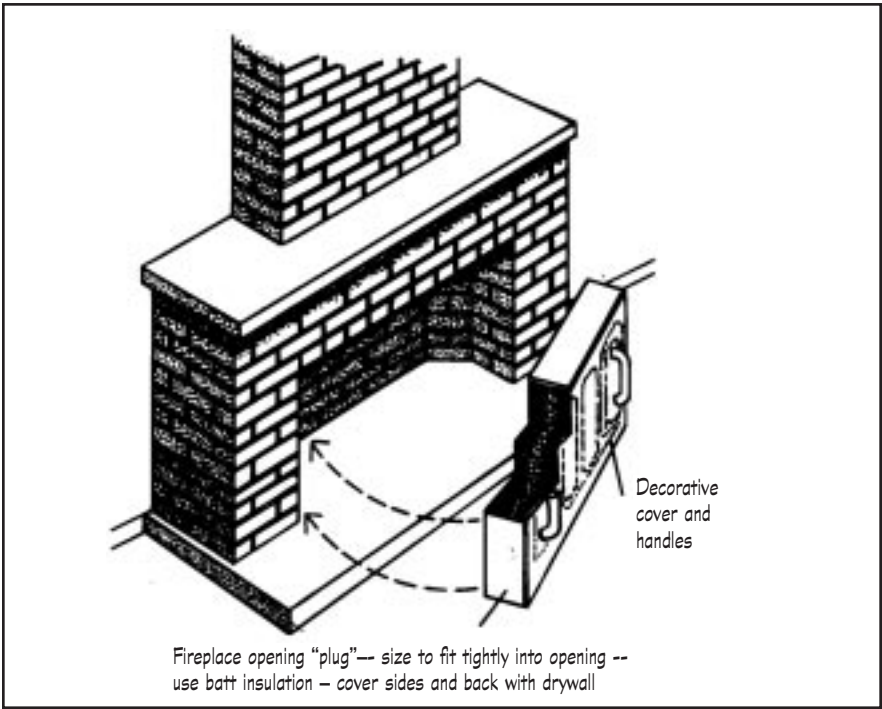

Figure 8:  
Install a decorative “plug” when the fireplace is not in use to prevent heated air from escaping from the heated room and up the chimney.

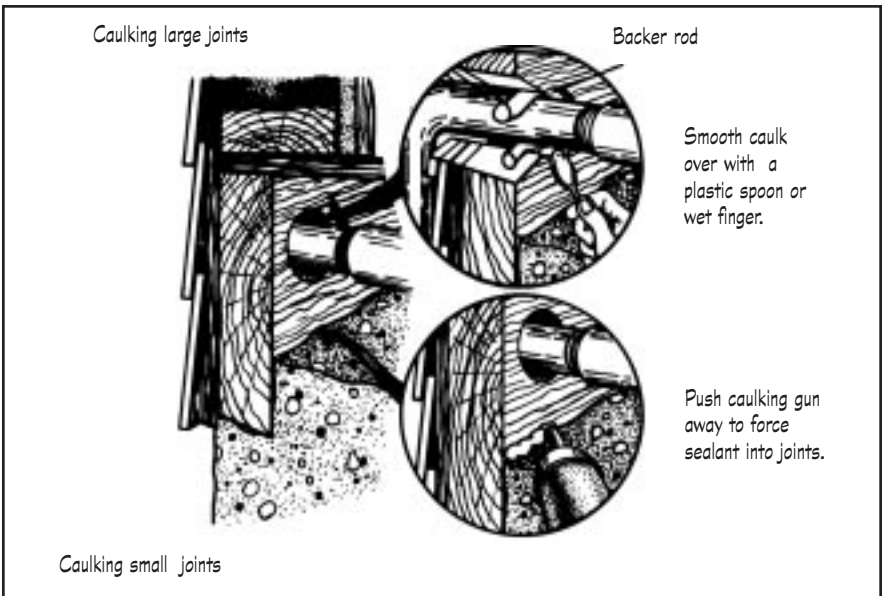

Figure 9:  
Apply caulk where two non-moving surfaces meet to cut heat losses.

but make sure they are closed when not in use by feeling for any air leaks or drafts. A dust or lint buildup around the closing flap or a bent, sticking hinge may be preventing the flap from closing completely. Clean and adjust the dampers to correct this problem. An old toothbrush works well as a cleaning tool. The complete duct run from your clothes dryer should also be cleaned regularly to prevent a lint buildup within the duct as well as around the damper.

The damper in the fireplace chimney should also fit tightly. Using a light, check for any gaps caused by debris buildup, warping or poor construction. This damper cannot be weatherstripped, or have gaskets, but can be cleaned or adjusted for a better fit. Another alternative would be to install a new damper on the top of the chimney. You can also build a decorative, insulated fireplace “plug” to insert into an unused firebox opening (see Figure 8). The plug will prevent heated room air from constantly rising up the fireplace chimney around a poorly fitting damper.

**Caulking**

Caulk is applied where two non-moving surfaces meet, such as at sill plates or duct outlets. Caulking requires a little more effort and skill than weatherstripping, but is just as effective in cutting heat losses. Some areas, such as plumbing stacks, chimneys or electrical outlets, require specialized or combination weatherstripping and caulking techniques.

Houses are built of a number of different materials. Because these materials expand and contract at different rates with temperature and moisture changes, cracks and gaps may occur. Exterior gaps are a concern because water can penetrate the structure and cause deterioration. Interior gaps are a concern because air leakage causes heat loss, and the heated air carries moisture which may condense in the wall and cause structural damage.

The best place to seal with caulk is on the inside, to prevent moisture accumulating in wall and ceiling cavities. Interior sealants, though not subject to the same severe weather conditions as exterior types, should be chosen for their ability to maintain a good degree of flexibility and adhesion over a long period of time.

The preferred type of interior sealant will depend on its use. Factors to consider include whether the sealant will be exposed or concealed, the width of gap, types of adjacent materials and whether a high degree of flexibility is required. Table 3 gives the characteristics of available caulking materials.

Before using caulking materials, note the following points:

- Remove old caulk completely.
- Make sure all surfaces are dry and free of dirt, loose materials, grease or oil. Wipe with rubbing alcohol.
- Do not apply caulk at temperatures below (50°F) unless otherwise specified on the label.
- Always read the label to see if the caulk you are using is flammable, irritating to the skin or gives off dangerous vapors, and handle it accordingly.
- If priming is required, paint two light coats of alcohol shellac or a primer recommended by the manufacturer.
- Choose a caulking material suitable to the size of the crack to be filled and compatible with the materials it is to adhere to.
- Tape the edges of the crack to keep caulk off adjoining surfaces.

Practice may be required before you can create a neat, uniform bead when using a caulking gun. The nozzle should be cut at a 45 degree angle. Since the nozzle is tapered, cut it at the point that will give the width you require – near the narrow end for a small bead, farther up for a wider bead. The caulking material should be pushed out the nozzle as you apply steady pressure on the trigger, holding the angle of the gun constant and moving ahead at an even rate. The resulting bead should provide a good seal. Be careful to have enough caulking to accommodate shrinkage or joint movement (Figure 9).

Smooth the bead with a wet finger or use a plastic spoon for toxic materials such as silicone or oil based caulk.

For gaps larger than 3/8 inch in width or depth, polyurethane foam can be used. Other caulks will

require a backer material such as rope caulking or foam weatherstripping to reduce the depth. Caulking will crack if you do not completely fill the gap.

When you are finished, seal the tip of the caulking gun tightly after cleaning out excess caulk. Shelf life for most unopened caulk is two years. For clean-up, check directions on the tube.

**Sealing the attic and rim joist space areas.** Large amounts of air can leak into a house through the rim joist area in the basement. The incoming air is heated by the interior of the house and then is lost into the attic through penetrations into the attic (called attic bypasses). The first and most important step to reduce this heat loss is to seal the attic bypasses. We do not recommend that you seal basement air leaks until you have installed sealed or direct vent combustion appliances, because these actions can impair the safe operation of gas burning appliances. For more information see the Attic Bypasses, Basement Insulation, and Combustion Air Home Energy Guides.

**Sealing around window and door openings.** The installation space or rough opening around windows and doors is a major area of air leakage. Usually insulation has been stuffed into a crack; this insulates but does not stop the air flow. This leakage can be stopped by using the method detailed in Figure 10.

### Tip:

Caulk is cheap— and it provides a big return on investment and comfort as well.

Figure 10:

Pre-formed foam rods and expanding urethane foam can be used to seal the gap between the window and the wall.

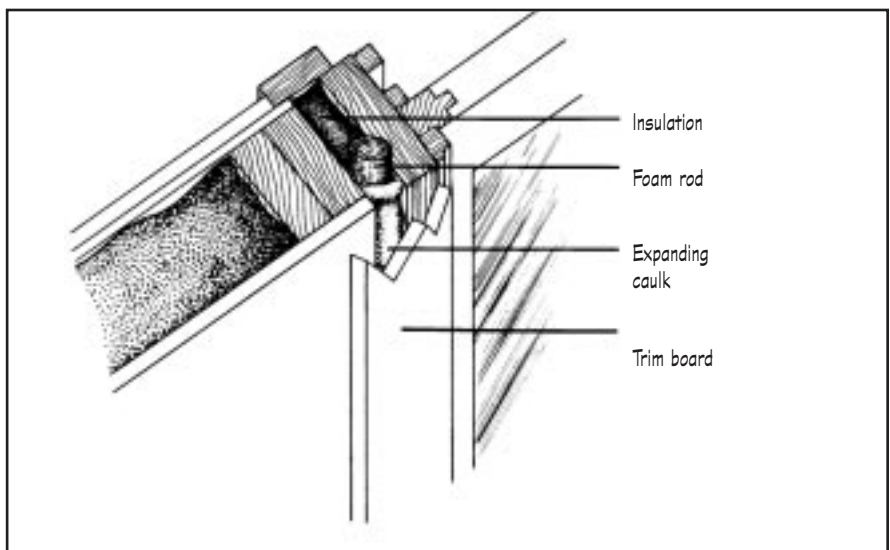

## Caulking Steps

- Check potential areas of air leakage and identify the worst sources.
- Begin with caulking the attic and attic bypass areas.
- Weatherstrip around moving parts of windows, doors and hatches.
- Caulk around door and window trim.
- Check vents and dampers on fans, fireplaces and dryers.
- Caulk cracks and around outlets, vents and pipes penetrating the house exterior. Remember to do ceiling penetrations as well.
- Test again for effectiveness of sealing, or hire a professional to conduct a blower-door test for you or arrange for an energy "audit" through your electric or gas utility or community energy program.
- Increase the fresh air supply to control condensation, especially on windows. This may require adding a fresh air supply to older homes.

It is most convenient to improve the seal around doors and windows of older homes when the trims are removed for repainting or are being replaced.

**Sealing loose panes of glass.** If any glass panes are loose in their wood frames, new caulking is required to stop air leakage. Putty compounds and glazing points are most often used and are the least expensive solution. For information on reglazing, consult the home repair books in your local library, or locate a window dealer in the yellow pages. (Look under Window, replacement.)

Glass panes in metal and vinyl frames are best sealed with vinyl strips. The strips are durable and should not require replacement during the life of the window.

**Sealing wall outlets and switches.** Outlets and switches on walls are another source of heat loss. Some tests indicate that up to 20 percent of the total air leakage heat losses in existing houses can occur through the outlets. If there is a gap, use commercially available, inexpensive gaskets between the plate and wall.

Disconnect the power to any outlets you are working on. Electrical codes forbid placing any object inside the boxes, so all sealing must be external. Child "safety plugs" can also be placed into unused outlets to stop air flow through the outlet holes.

If you are removing wall finishes, renovating or installing new wiring, you should install a vapor barrier behind new electrical boxes. Use the commercially available polyethylene box covers. Seal the box covers to the wall vapor barrier with an acoustical sealant before covering the walls.

Seal other penetrations into the house, such as plumbing and electrical openings, with caulk.

## Conclusion

The costs associated with weatherstripping and caulking are small. Installation takes time, but is not difficult and fuel savings are considerable. Improving air tightness should be considered a must for making your home comfortable and energy efficient.



## Table ONE: Weatherstripping

### Tape (Cloth or plastic)

- use on any non-opening window or door
- good for one season only
- quick and easy to install
- remains in full view
- may remove paint when peeled off
- inexpensive

### Gasket (Felt)

- use on windows, doors and attic hatch for compression fits
- poor durability and air seal
- must be nailed, stapled or glued
- made from wool, hair, cotton or polyester
- inexpensive

### Gasket (Foam adhesives)

- use on windows, doors and attic hatch for compression fits
- available in open or closed-cell types
- closed-cell is more durable
- quick and easy to install
- hidden from view
- moderately expensive

### Gasket (EPDM rubber adhesive)

- use on windows and doors for compression fit
- good durability and air seal
- quick and easy to install
- hidden from view
- inexpensive
- good durability

### Gasket (Foam on attachment strip)

- use on windows and doors for compression fit
- more durable than adhesive type
- must be nailed or screwed
- hidden from view
- moderately expensive
- good performance

### Tubular (Filled core)

- for windows or doors
- good durability and air seal
- must be nailed or stapled; in full view
- made with rubber, plastic or vinyl
- difficult to compress
- moderate to expensive

### Tubular (Hollow core)

- for windows or doors
- good durability and air seal
- must be nailed or stapled; in full view
- made with rubber or vinyl
- moderately expensive

### Tubular (Hollow on attachment strip)

- use on windows and doors
- good durability and air seal
- usually nailed or screwed; in full view
- slotted holes allow for readjustment
- made of rubber or vinyl with aluminum or vinyl attachment strips
- expensive

### Strip (Tension-spring metal or V-strip)

- use on windows and doors; especially good for the gap where the sash of double hung windows meet
- excellent durability and good seal
- must be nailed if metal, or adhesive
- if vinyl, invisible when installed
- hidden from view
- double strip vinyl available for a better seal
- moderate to expensive

### Strip On attachment (pile or fin)

- use on windows and doors; especially good for sliding windows
- moderate to good seal and durability
- must be nailed or screwed in full view
- made with vinyl rubber or polyester pile with fin seal on a wood, vinyl or aluminum attachment strip
- moderate to expensive

### Specialty (Spring loaded)

- use on windows or doors
- excellent durability and seal
- must be nailed or screwed
- made with aluminum and vinyl
- very expensive

### Specialty (Magnetic strip)

- use on windows and doors
- excellent durability and seal
- must be nailed or screwed
- made with aluminum and vinyl
- very expensive

## Air leaks IN, air leaks OUT: Which is worse?

The amount of air leaking in always equals the air leaking and being exhausted out. While air leaking in may sometimes cause uncomfortable drafts, it actually has unseen benefits! If an exhaust fan is running (such as a clothes dryer) air must be leaking in to supply the exhaust fan or your house may become "depressurized," possibly resulting in back drafting of the water heater, furnace or fireplace.

Air leaking out is bad, even though you won't be able to feel it. In the winter, warm, moist air is rising and leaking out of upper floors. This is bad because as warm, moist air is leaking out it is carrying moisture with it. This moisture can condense into your walls and attic, causing deterioration to the structure. Furthermore, warm air leaking into the attic is the major cause of ice dams (see the Home Energy Guide Ice Dams).

When sealing your home for air leaks, the first priority is to stop air from leaking out. This means starting with sealing attic bypasses and air leaks in upper story walls.

## Can you over-seal your home?

It is difficult, but possible to seal an existing house to the point that the air supply to combustion equipment is restricted or humidity and condensation problems occur. In newer homes, or with a furnace replacement, there should be a separate combustion air supply installed for the furnace so that sealing the home will not affect performance.

All homes should have mechanical ventilation so that kitchen and bathroom moisture can be sent rapidly out of the house. Excessive condensation, such as large amounts of ice on the inside of windows or mold growing on indoor surfaces, may also have causes other than a tight house. Storing wood in the house, boiling water for meals and other lifestyle issues can lead to indoor moisture problems. If you have excessive moisture, call the Energy Information Center and ask for a Home Moisture guide.

## Table TWO: Weatherstripping for door bottoms

### Saddle Threshold

- requires minimum clearance of 5/8 inch
- may have adjustable insert (up to 1-1/4 inch)
- check that replacement gaskets are available
- good durability and seal
- made with vinyl or rubber and aluminum base
- installed with screws
- expensive
- look for a thermal break on metal thresholds

### Bumper Threshold

- bottom clearance not required
- can be damaged by trapped stones, etc.
- check that replacement gaskets are available
- good durability and seal
- made with vinyl or rubber on a vinyl, wood or aluminum attachment
- installed with screws on interior of door
- moderately expensive

### Door Bottom

- requires minimum clearance of 1/4 to 1/2 inch
- some types can be used as a threshold
- check that replacement gaskets are available
- must remove door to install
- made with rubber, metal, vinyl or felt on aluminum or vinyl base
- moderately expensive

### Door Sweeps

- good to use for uneven floors
- adjusts for sweeping over deep carpet
- easy to attach; may be adhesive backed, nailed or screwed
- attach to inside face of in-swinging door
- fair to good durability and seal
- made with vinyl, rubber or polyester pile on an aluminum vinyl or wood attachment strip
- generally the least expensive type

## Table THREE: Types of Caulk

### Oil/Resin Base

- durable for 1 or 2 years
- bonds to most surfaces although may stain unprimed wood surfaces
- difficult to apply; sticky
- takes up to 1 year to cure
- forms hard surface when dry
- should be painted
- low cost

### Latex base (acrylic or non-acrylic)

- durable for up to 10 years
- bonds well to porous surfaces such as wood or concrete but not to metal
- easy to apply; does not require primer
- do not use in high moisture environments (showers); susceptible to mildew
- fast curing
- forms hard or flexible surface when dry; use for small movement joints between similar materials
- comes in colors or can be painted
- most types clean up with water, or use paint thinner
- medium cost

### Butyl Rubber

- durable for 5 to 15 years
- bonds well to all surfaces but tends to shrink
- does not require a primer
- will stick to air/vapor barrier
- more difficult to apply
- slow to cure
- flexible when dry; use for small-movement joints
- clean-up with paint thinner
- can be painted; also comes in colors
- medium cost

## (con't) Table THREE: Types of Caulk

### Elastomeric (silicone, polysulphide)

- durable for more than 20 years
- bonds to most surfaces; requires primer for some plastics, masonry and other porous surfaces (specialized sealants are available)

### Elastomeric

- won't seal over itself without a primer
- difficult to apply in cold weather
- may be irritating during application and curing
- high moisture resistance
- takes up to 3 days to cure
- nontoxic when cured
- ventilate area when applying
- little shrinkage; remains flexible when dry; use for large movement joints
- needs special cleaner for tools and hands if not cleaned with water before curing
- high cost

### Polyurethane foam

- available in aerosol cans
- specialized for large gaps
- when applying, make sure area is well ventilated
- use gloves when applying
- requires care when applying as it expands 2-1/2 times
- may degrade in sunlight
- bonds to most surfaces
- requires a primer before use on pressure treated wood or vinyl
- flammable; must be covered by drywall on interior
- has high insulation value
- high cost

### Polyurethane, gunable

- use in standard caulk gun
- bonds to masonry
- may require primer
- may be thinned
- durable for up to 20 years
- paintable
- may take a long time to cure

### Acoustical sealant

- durable for more than 20 years
- only available in large tubes; needs large gun
- interior use only
- excellent for joining air/vapor barrier
- easy to apply, but messy
- non-hardening; must be covered
- need special cleaner (paint thinner) for tools and hands
- low cost

### Rope or cord

- specialized product for larger gaps
- if not sealed, can be used temporarily, then removed and reused
- should be protected by sealant or covering
- low cost

## Caulking Tips

It's advisable to seal "attic bypasses" first, before caulking windows and doors.

The best place to seal with caulk is on the inside.

This Home Energy Guide was adapted from the publication "Caulking and Weatherstripping," courtesy of Alberta Department of Energy and Natural Resources.

## Minnesota Department of Commerce

Suite 500  
85 7th Place East  
St. Paul, MN 55101-2198  
www.commerce.state.mn.us

## Energy Information Center

Twin Cities:  
651-296-5175

TTY: 651-297-3067

Statewide toll free:  
1-800-657-3710

E-mail:  
energy.info@state.mn.us

This information will be made available, upon request, in alternative formats such as large print, Braille, cassette tape, CD-ROM.

This publication was produced with funds from a U.S. Department of Energy State Energy Program grant. However, any opinions, findings, conclusions, or recommendations expressed herein are those of the author and do not necessarily reflect the views of the Department of Energy.



MINNESOTA  
DEPARTMENT OF  
COMMERCE

061501C

## Minnesota Home Energy Guides

This guide is one in a series of publications designed to help Minnesotans save energy in their homes. Copies of the titles listed below are available by calling or contacting the Minnesota Department of Commerce.

**CD-ROM** contains all of the Home Energy Guides as well as several other publications of interest to homeowners, builders and contractors.

**Appliances** advises consumers on what to look for in energy efficient appliances and includes information on efficient operation and maintenance of refrigerators, freezers, washers, dryers, dishwashers, cooktops, ovens, and home office equipment.

**Attic Bypasses** explains how to find those "hidden air passageways" and fix them to prevent costly heat loss and damage to roofs, ceilings, walls, and insulation.

**Basement Insulation** discusses the pros and cons of interior vs. exterior insulation and provides detailed how-to instructions.

**Caulking and Weatherstripping** describes how to identify sources of air leaks, lists various types of caulk and weatherstripping, and provides illustrated how-to-apply instructions.

**Combustion and Makeup Air** describes the causes of dangerous combustion air problems and tells how to install an outside combustion air supply. It also tells how to test your home for combustion air problems.

**Energy Saving Landscapes** describes how to use trees and shrubs for long-term energy savings, and lists trees appropriate for energy-savings.

**Home Cooling** tells you how to cool without air conditioning, and provides information on buying and operating energy efficient air conditioners.

**Home Heating** describes proper maintenance techniques and helps you become an educated shopper if you are buying a new heating system.

**Home Insulation** helps the homeowner evaluate the benefit of added insulation, providing information on buying and installing insulation.

**Home Lighting** looks at new technologies for residential lighting, identifying four basic strategies and providing examples for putting them into practice.

**Home Moisture** describes symptoms of moisture problems, lists common indoor and outdoor causes, and discusses preventive and corrective measures.

**Indoor Ventilation** describes the types of home mechanical ventilation systems that are available, the amount of ventilation air needed, and how best to operate and maintain the system.

**Low Cost/No Cost** addresses the often overlooked energy saving tips for all areas of your home.

**New Homes** discusses a wide range of options for increasing energy efficiency beyond the normal building code requirements. Subjects covered include insulation, ventilation, air-vapor controls, heating and cooling, windows, doors, and appliances.

**Water Heaters** helps you determine whether to buy a new water heater or improve the old one. It explains the efficiency of different types of water heaters and provides installation tips.

**Windows and Doors** helps you decide whether to replace or repair windows or doors and gives a good summary of energy efficient replacement options.

**Wood Heat** offers advice on purchasing and installing a wood stove, with special emphasis on safety.